

Crystal Structure of Tris(tetra-*n*-butylammonium) Tri- μ -benzenethiolato-bis{tri- μ -sulphido- $[\mu_3$ -sulphido-tris(benzenethiolatoiron)]molybdenum} $[\text{Bu}^n_4\text{N}]_3[\{(\text{PhSFe})_3\text{MoS}_4\}_2(\text{SPh})_3]^-$; an Fe_3MoS_4 Cubic Cluster Dimer

By GEORGE CHRISTOU, C. DAVID GARNER,* and F. E. MABBS

(Department of Chemistry, Manchester University, Manchester M13 9PL)

and TREVOR J. KING

(Department of Chemistry, Nottingham University, Nottingham NG7 2RD)

Summary An X-ray crystallographic study shows that the anion $[\{(\text{PhSFe})_3\text{MoS}_4\}_2(\text{SPh})_3]^{3-}$ contains two Fe_3MoS_4 'cubes' linked across their molybdenum centres by three μ_2 -benzenethiolato-groups.

THE structure and function of the various molybdoenzymes continues to attract much attention.¹ Shah and Brill have reported recently definitive isolations of molybdenum cofactors from the nitrogenase MoFe protein of *Azotobacter vinelandii*² and from buttermilk xanthine oxidase.³ Analytical data obtained for the first of these cofactors suggest that iron, molybdenum, and acid-labile sulphur are present in the ratios 8:1:6. Extended X-ray absorption fine structure (EXAFS) studies⁴ indicate that the environment about the molybdenum in the cofactor is very similar to that in the intact MoFe protein from *A. vinelandii* and *Clostridium pasteurianum*. The structural inferences placed upon these EXAFS data suggest that the molybdenum is surrounded by 3 or 4 sulphur atoms at 2.35 Å, 1 or 2 sulphur atoms at 2.49 Å, and 2 or 3 iron atoms at 2.72 Å. These details lead naturally to the suggestion that nitrogenase may contain Mo-Fe-S 'cubes'. We have been interested in the characterisation and reactions of compounds which may contain such units. Here we report the crystal structure of one novel species of this type $[\text{Bu}^n_4\text{N}]_3[\{(\text{PhSFe})_3\text{MoS}_4\}_2(\text{SPh})_3]^-$ (1); certain properties of this compound have been described earlier.⁵

heavy atom Patterson and Fourier procedures and refined by full-matrix least-squares methods, with anisotropic temperature factors for the Mo and Fe atoms and isotropic temperature factors for the C, N, and S atoms. At the current stage of refinement $R = 0.088$. Hydrogen atoms have not been included and two of the carbon atoms of the cations have still to be located with certainty.

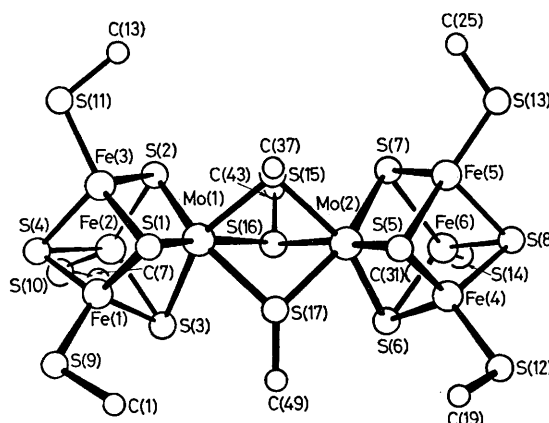
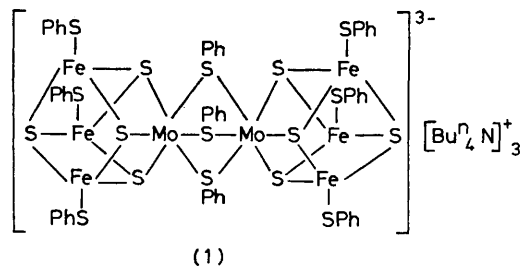

FIGURE. Representation of the atomic arrangement for the $[\{(\text{PhSFe})_3\text{MoS}_4\}_2(\text{SPh})_3]^{3-}$ unit; for clarity all the carbon atoms of the benzene rings, other than those bonded to a sulphur atom, have been omitted.



The title compound (1) crystallises in the monoclinic space group Cc , with four formula units per unit cell of dimension $a = 16.452(2)$, $b = 27.469(4)$, $c = 26.754(4)$ Å, and $\beta = 94.81(2)^\circ$. Single crystal X-ray diffraction data were collected on a Hilger and Watts four-circle diffractometer using Mo- K_α radiation; 3564 reflections were considered observed and used in the solution and refinement of the crystal structure. The structure was solved by normal

A representation of the structure of the anion is shown in the Figure. † This unit consists of two Fe_3MoS_4 cubane-like units linked across their molybdenum centres by three μ_2 -benzenethiolato-groups. The overall structure of the $[\{(\text{SFe})_3\text{MoS}_4\}_2\text{S}_3]$ framework closely approximates to D_{3h} point symmetry. The MoS_6 units correspond closely to C_{3v} point symmetry; the arrangement of these co-ordinated sulphur atoms derives from an octahedron by distortion along a three-fold axis, with the Mo-S bonds to the μ_2 -benzenethiolato-groups being significantly longer than those to the μ_3 -sulphido-groups. The three sulphido-ligands and the terminal benzenethiolato-group produce an effectively tetrahedral arrangement of sulphurs about each iron atom.

There are few significant differences in the interatomic dimensions between the crystallographically non-equivalent halves of the anion. Those dimensions involving Mo, Fe, and S atoms, averaged for the whole unit, are presented in the Table together with the corresponding dimensions⁶ of

† The atomic co-ordinates for this structure are available on request from the Director of the Cambridge Crystallographic Data Centre, University Chemical Laboratory, Lensfield Road, Cambridge CB2 1EW. Any request should be accompanied by the full literature citation for the communication.

$[\text{Fe}_4\text{S}_4(\text{SPh})_4]^{2-}$. A comparison of these data shows that substitution of molybdenum for an iron atom of an Fe_4S_4 'cube' results in only minimal changes in the detailed

TABLE. Comparison of certain interatomic dimensions^a (Å) and angles (degrees) of $[\text{Bu}^n_4\text{N}]_3[\{(\text{PhSFe})_3\text{MoS}_4\}_2(\mu_2\text{-SPh})_3]$ and $[\text{Me}_4\text{N}]_2[\text{Fe}_4\text{S}_4(\text{SPh})_4]$ ^b

$[\{(\text{SFe})_3\text{MoS}_4\}_2\text{S}_3]$ unit		$[(\text{SFe})_4\text{S}_4]$ unit ^b	
Fe-S _c	2.25(3)	Fe-S _c	2.286(15)
Mo-S _c	2.34(2)		
Fe-S _t	2.25(3)		
Mo-S _b	2.58(2)		
Fe - - - - Fe	2.69(2)	Fe - - - - Fe	2.736(6)
Mo - - - - Fe	2.71(2)		
$\angle \text{S}_t\text{-Fe-S}_c$	112.9(4.8)	$\angle \text{S}_t\text{-Fe-S}_c$	115.1(8.6)
$\angle \text{Fe-S}_c\text{-Fe}$	73.4(1.1)	$\angle \text{Fe-S}_c\text{-Fe}$	73.5(0.6)
$\angle \text{Mo-S}_c\text{-Fe}$	72.5(0.7)		
$\angle \text{S}_c\text{-Fe-S}_c$	105.5(2.7)	$\angle \text{S}_c\text{-Fe-S}_c$	104.3(0.8)
$\angle \text{S}_c\text{-Mo-S}_c$	102.7(0.5)		
$\angle \text{Fe-Fe-Fe}$	60.2(0.7)	$\angle \text{Fe-Fe-Fe}$	60.0(0.2)
$\angle \text{Fe-Mo-Fe}$	59.5(0.6)		

^a S_c = μ_3 -sulphido-sulphur; S_t = terminal benzenethiolato-sulphur; S_b = μ_2 -benzenethiolato-sulphur.

^b Ref. 6.

geometry. The Mo-S distances are similar to those which obtain for sulphido (*ca.* 2.3 Å)¹ and benzenethiolato (*ca.* 2.6 Å)⁷ groups bridging between two molybdenum(v) atoms. However, the Mo - - - - Mo separation of 3.685(3) Å in this dimer is considerably longer than those separations typically observed for oligomeric molybdenum complexes in which two or more ligands bridge the molybdenum centres. The overall environment of the molybdenum atoms in the $[\{(\text{PhSFe})_3\text{MoS}_4\}_2(\text{SPh})_3]^{3-}$ complex resembles that suggested⁴ for this metal in nitrogenase, these similarities being particularly marked for the Mo-S and Mo - - - - Fe separations within the 'cubes'.

The assignment of formal oxidation states for the metal atoms within the unit reported here requires further information. The sum of these oxidation states for each Fe_3Mo unit is XI; thus the possibilities appear to range from (3Fe^{II} + Mo^V) to (3Fe^{III} + Mo^{II}).

We thank the S.R.C. for the award of a Post-Doctoral Fellowship (to G.C.).

(Received, 23rd May 1978; Com. 551.)

¹ E. I. Stiefel, *Progr. Inorg. Chem.*, 1977, **22**, 1, and references therein.

² V. K. Shah and W. J. Brill, *Proc. Nat. Acad. Sci. U.S.A.*, 1977, **74**, 3249.

³ P. T. Pienkos, V. K. Shah, and W. J. Brill, *Proc. Nat. Acad. Sci. U.S.A.*, 1977, **74**, 5468.

⁴ E. A. Stern, *Phys. Rev.*, 1974, **B10**, 3027; S. P. Cramer, Ph.D. Thesis, University of Salford, 1977.

⁵ G. Christou, C. D. Garner, and F. E. Mabbs, *Inorg. Chim. Acta Letters*, in the press.

⁶ L. Que, Jr., M. A. Bobrik, J. A. Ibers, and R. H. Holm, *J. Amer. Chem. Soc.*, 1974, **96**, 4168.

⁷ K. Yamanouchi, J. H. Enemark, J. W. McDonald, and W. E. Newton, *J. Amer. Chem. Soc.*, 1977, **99**, 3529.